

HC3 520AJ

ARTICULATING HI-CAPACITY

BOOM LIFT



HC3

KEY SPECS

Platform Height
16 m

Horizontal Outreach
10 m

Platform Capacity
Restricted 340/454 kg
Unrestricted 300 kg



Tilt
5 Degrees

KEY FEATURES

- Maximum productivity- 3 people allowed into the basket in 3 working zones at the same time, from 300 kg unrestricted up to 454 kg restricted.
- Enhanced Platform Control- an LCD screen provides better visibility in the direct sunlight and an automatic selection of the capacity zone based on the load in the basket
- No weight calibration with the new load sensing system
- Chassis tilt indicator of 5° with light alarm

ACCESSORIES & OPTIONS

- 0.76 m x 1.22 m swing gate or drop bar platform
- 0.76 m x 1.52 m swing gate or drop bar platform
- 0.92 m x 1.83 m swing gate or drop bar platform
- 0.76 m x 0.92 m drop bar platform
- 13 mm air line to platform
- 4000W 50Hz GEN (DEUTZ Stage V)
- 33 x 12-20 low profile, SOLID, non-marking
- 33/1550 x 16.5 FF
- 14 x 17.5 foam filled tyres
- 14 x 17.5 FF (Non-marking)
- Light package³
- Special Hydraulic Oils
- Flashing amber beacon
- Plugs & Sockets
- Hostile environment package²
- Skyguard with beacon
- Skyguard without beacon
- Skybar
- Skyeye
- Cold Weather package⁴
- ClearSky Locate
- ClearSky CAN
- Beacon Alert (Blue & Red)

STANDARD SPECIFICATIONS

Performance

Working Height	18 m
Platform Height	16 m
Horizontal Outreach	10 m
Working Outreach **	10.65 m
Up and Over Height	7.3 m
Below Ground Reach	0.41 m
Swing	355° (Non-Continuous)
Platform Capacity (Restricted)	🧑🧑🧑 340 kg/ 454 kg
Platform Capacity (Unrestricted)	🧑🧑 300 kg
Platform Rotator (Hydraulic)	173°
Jib - Overall Length	1.24 m
Jib - Range of articulation	145° (+76°/ -69°)
Machine weight *	8,618 kg
Maximum Ground Bearing Pressure	7.21 kg/cm ²
Drive Speed 4WD	6.84 km/h
Gradeability 4WD	45%
Axle Oscillation	0.11 m
Tilt Cut Out	5°
Turning Radius - Inside	2.46 m
Turning Radius - Outside	5.11 m

* Certain options or country standards may increase weight and/or dimensions

** Incl. 0.65 m outreach beyond platform

Engine

Diesel Engine - Deutz D2.9L4 Stage V	36.4kw (48.8hp)
Fuel Tank Capacity	60.6 L

Hydraulic System

Tank Capacity	56.8 L
Auxiliary Power	12V DC

Tires

Tire Size / Type (Non-Marking)	33X12 D610 FF
--------------------------------	---------------

STANDARD FEATURES

- 0.76 m x 1.83 m side entry
- Multiple function operation
- Proportional Controls
- Full proportional drive joystick control with integral thumb steer switch
- Full proportional main boom and swing joystick control
- Multiple speed control for lower boom, telescope and platform rotate
- Selectable creep speed on drive / lift and swing functions
- 1.24 m articulating jib
- 180 degree powered platform rotator
- Platform console machine status light panel¹
- Load sensing system
- AC power cable to platform
- Dura Tough turnable hoods
- Swing-out engine tray
- Control ADE® (Advanced Design Electronics) System
- Four wheel drive
- Horn
- Hydraulic Oil Cooler
- 5 degree tilt alarm and indicator light
- 33 X 12 D610 FF
- Oscillating Axle
- Lifting/tie down lugs
- Hour meter
- Ground control selector switch with key lock
- All motion alarm
- Platform power USB
- 110V-AC Receptacle in the Platform
- Skyline
- Platform tool tray
- 12V-DC auxiliary power

1 Provides indicator lights at platform control console for system distress, low fuel, tilt light, and foot switch status.

2 Includes console cover, boom wipers and cylinder bellows.

3 Includes platform mounted work lights and head & tail lights.

4 Includes battery blanket, hydraulic tank heater and block heater

HC3 520AJ

ARTICULATING HI-CAPACITY

BOOM LIFT



DIMENSIONS

All dimensions are approximate

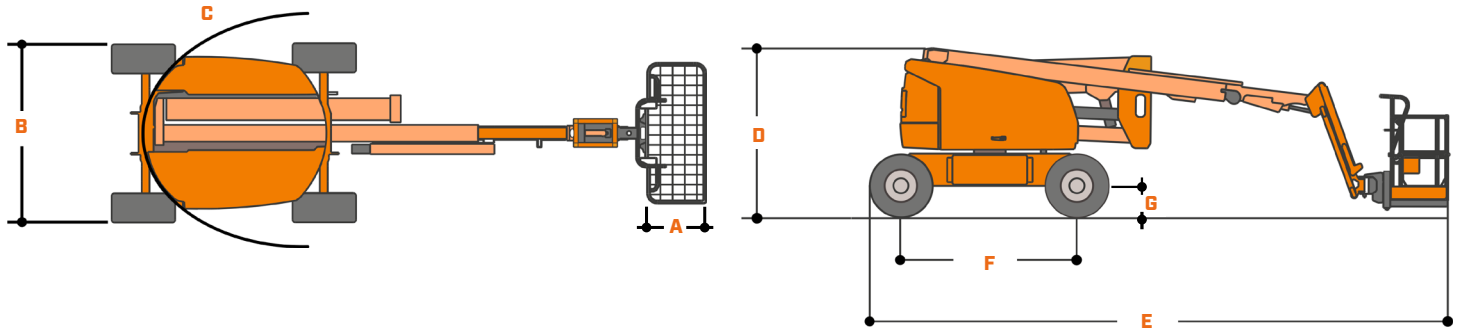

A. Platform Size	0.76 m x 1.83 m
B. Overall Width	2.35 m
C. Tailswing (working condition)	Zero

D. Stowed Height	2.27 m
E. Stowed Length	7.8 m
F. Wheelbase	2.36 m
G. Ground Clearance	0.42 m

REACH DIAGRAM

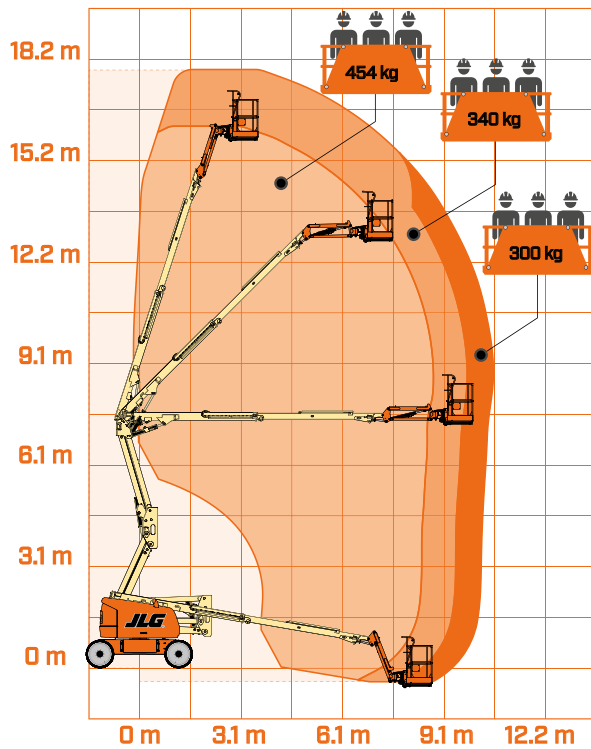

IMPORTANT

JLG is continually researching and developing products and reserves the right to make modifications without prior notice. All data in this document is indicative. Certain options or country standards will increase weight. Specifications may change to meet country standards or with the addition of optional equipment.

Due to continuous product improvements, JLG Industries reserves the right to make specification and/or equipment changes without prior notification.



JLG EMEA BV
 Polaris Avenue 63
 2132 JH Hoofddorp
 The Netherlands
 Tel.: +31 (0)23 565 5665
www.jlg.com

An Oshkosh Corporation Company